



OTHER RANGES WE OFFER TO OUR CUSTOMERS AT COMPETITIVE PRICES

### CABLE ASSEMBLIES

By offering unrivalled service combining flexibility of approach, immediate quotations and tailored solutions, we have established ourselves as the manufacturer of choice with many customers seeking quality cable assemblies at a competitive price.

[www.duplexcsa.co.uk/docs/Fcatalogue.pdf](http://www.duplexcsa.co.uk/docs/Fcatalogue.pdf)

[www.duplexcsa.co.uk/docs/TVcatalogue.pdf](http://www.duplexcsa.co.uk/docs/TVcatalogue.pdf)

[www.duplexcsa.co.uk/docs/capability%20brochure.pdf](http://www.duplexcsa.co.uk/docs/capability%20brochure.pdf)

[www.duplexcsa.co.uk/docs/bncbrochure.pdf](http://www.duplexcsa.co.uk/docs/bncbrochure.pdf)

[www.duplexcsa.co.uk/docs/minibncfinal.pdf](http://www.duplexcsa.co.uk/docs/minibncfinal.pdf)

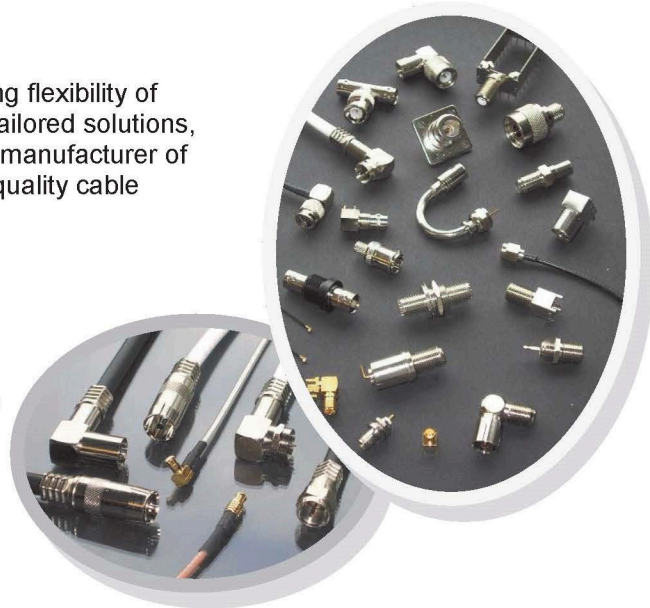

### MHF MINIATURE COAXIAL PRODUCTS—IPEX

The MHF family consists of 5 series of connectors with frequency range DC up to 6GHz (VSWR: 1.5 MAX). All are available with gold plating for superior performance and allow 360 degree cable mounting. Ultra low profile, from 1.2 to 2.5mm.

#### Major Applications

- Wireless LAN
- Mobile Phone
- Game Equipment

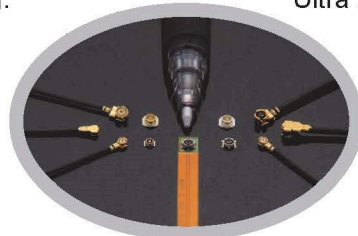

Access Point

- Antenna
- Note Book Computer
- Digital Appliance

[www.duplexcsa.co.uk/docs/webIPEX.pdf](http://www.duplexcsa.co.uk/docs/webIPEX.pdf)

### RF SHIELDING WITH OR WITHOUT CONNECTORS

Duplex CSA can deliver solutions ranging from a single piece shield to complex multi compartment connectorised frames with removable covers. We utilise a range of standard features that are tooled and ready to use.

Duplex CSA has the expertise to provide you with complete RF/EMI shielding solutions for all your PCB needs, from prototypes to volume productions.

[www.duplexcsa.co.uk/docs/custommweb.pdf](http://www.duplexcsa.co.uk/docs/custommweb.pdf)

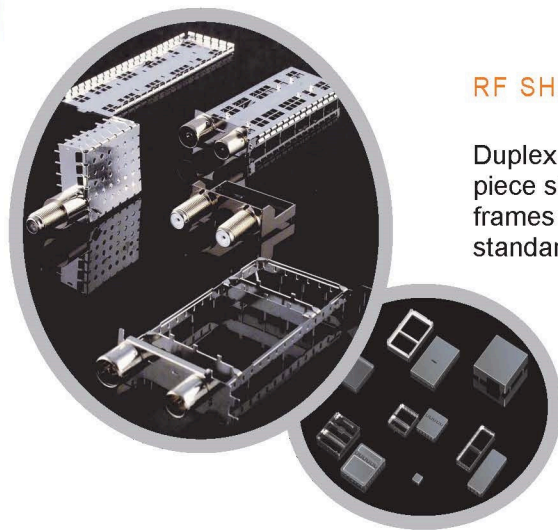

Are you are looking for something out of the ordinary?  
The options are only limited by your imagination.  
Give our team a call and make your ideas become reality.



## Duplex CSA

### F-SERIES

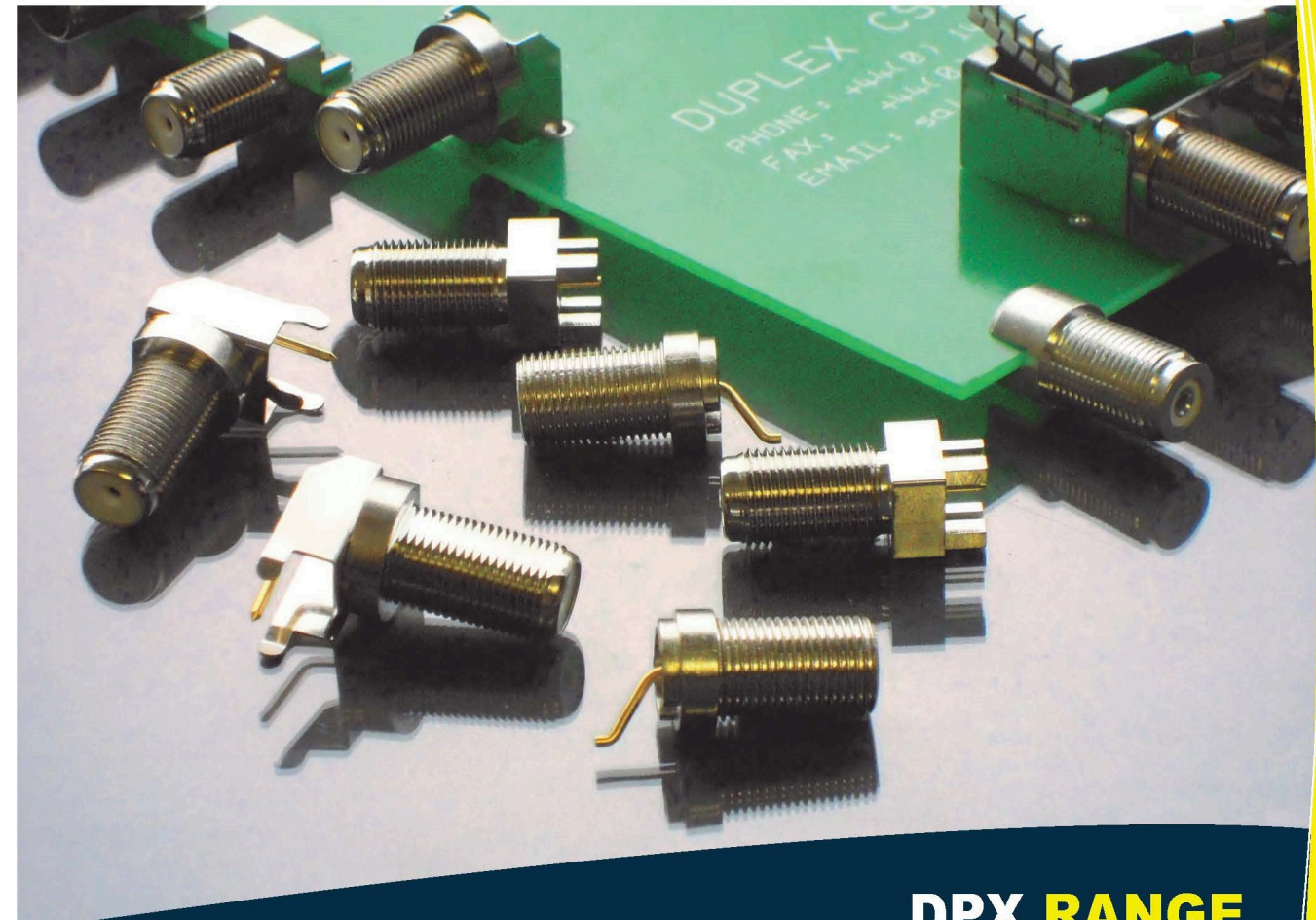

## DPX RANGE

### CONNECTING YOUR BUSINESS WITH THE CONNECTORS YOU NEED

As a market leading manufacturer **DUPLEX CSA** understands that quality of the connection, both mechanically and electrically, greatly influences the performance of our customers' equipment.

Our DPX product family takes this to the next level. These products share many of the features our traditional connector portfolio provides. In addition, the specific design of their component parts allied with the selection of high-quality materials, provide the enhanced performance that is now often needed as standard.

The DPX range is already being selected as the connector of choice with customers operating in the satellite set-top-box, high speed cable modem, HFC network and general high-end equipment markets.

The investment made by Duplex CSA in these types of solutions can be seen in the performance of our products, and is ready to be utilised to meet your projects' critical demands.

[sales@duplexcsa.com](mailto:sales@duplexcsa.com)

**Exceptional performance**

**Standard price**





# DPX RANGE

CONNECTING YOUR BUSINESS WITH THE CONNECTORS YOU NEED

EXCEPTIONAL PERFORMANCE - STANDARD PRICE

## THE DPX IS AVAILABLE IN

- F SERIES FEMALE
  - RIGHT ANGLE VERSION
  - STRAIGHT VERSION
  - EDGEMOUNT VERSION
  - SWAGE VERSION

## MATERIAL

- BODY: BRASS OR ZINC  
(PLATED WITH NICKEL OR TIN)
- PIN: SPRING BRONZE  
(PLATED WITH GOLD)
- INSULATION: PTFE OR DELRIN™
- CHARACTERISTIC IMPEDANCE: 75 Ω

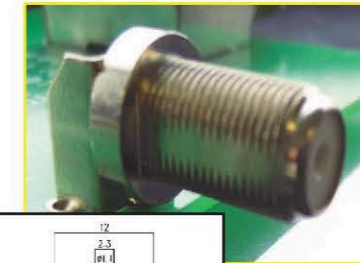
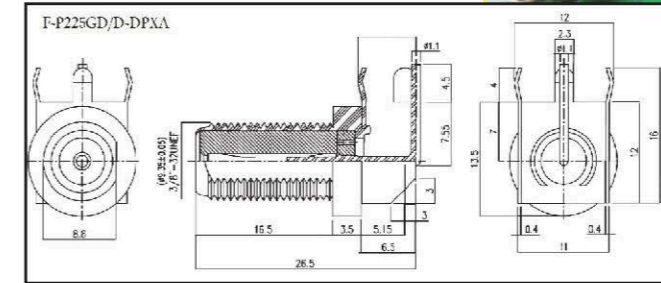
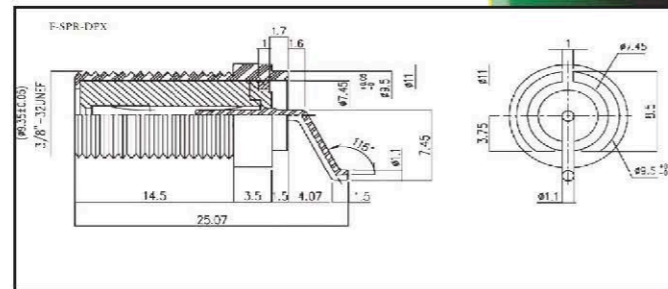
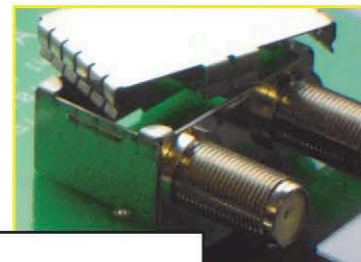

## TYPICAL PERFORMANCE COMPARISON:

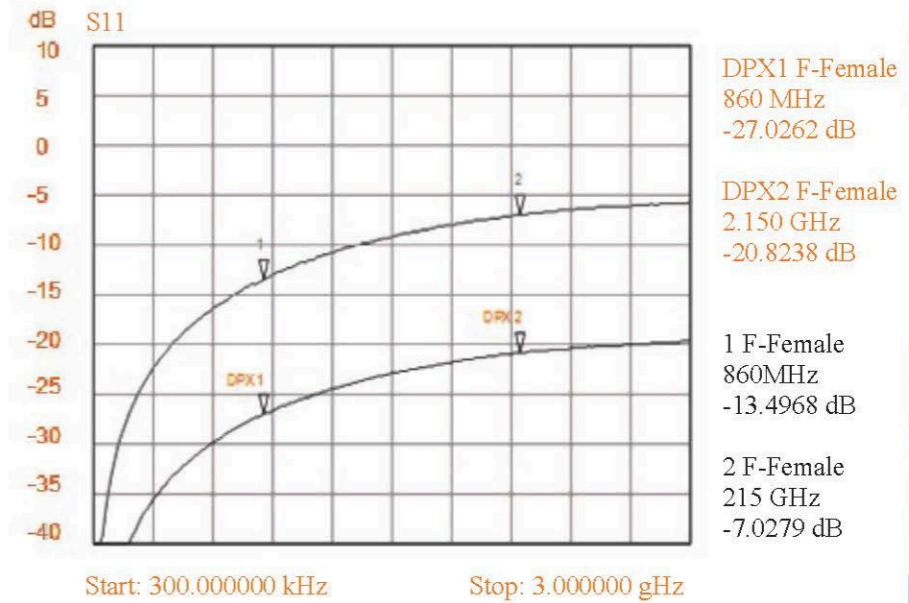

PREFERRED ITEMS  
OTHER TYPES  
AVAILABLE UPON  
REQUEST

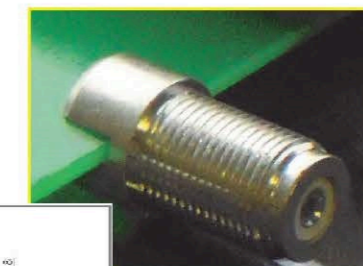
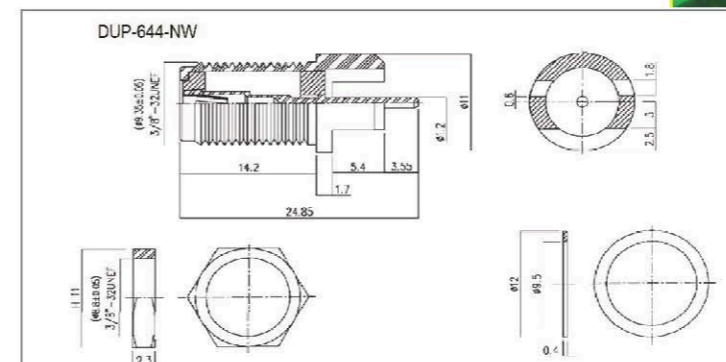
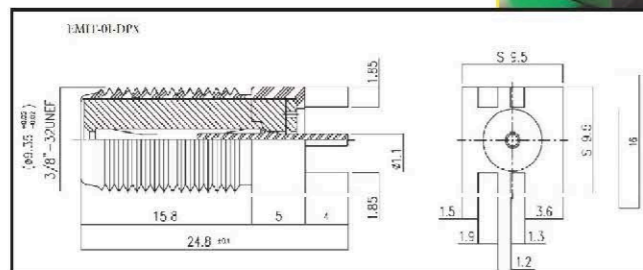
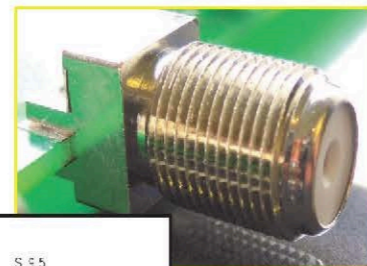

24 HOUR SAMPLING AVAILABLE

FOR PREFERRED ITEMS

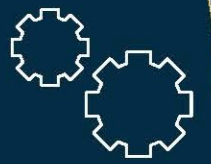

DUPLEX CSA SOLUTIONS

Offering our customers a highly personalised service. Enquiries and questions please call: +44 (0)1480 406200



WEB  
Visit us at:  
[www.duplexcsa.com](http://www.duplexcsa.com)

Email a member of our team at:  
[sales@duplexcsa.com](mailto:sales@duplexcsa.com)

Or follow us on Facebook and 'like' our page:  
[www.facebook.com/DuplexCSA](http://www.facebook.com/DuplexCSA)